

**North American Free Trade Agreement
Land Transportation Standards Subcommittee**

***Highway Safety Performance Criteria In Support of
Vehicle Weight and Dimension Regulations:***
Candidate Criteria & Recommended Thresholds

**Working Group 2 - Vehicle Weights and Dimensions
Report of the LTSS 2 Project Group**

**Working Draft for Consultation
*November 1999***

Preface:

This discussion paper has been prepared solely for the purposes of initiating discussion on the concept and potential application of highway safety performance criteria as components of vehicle weight and dimension policies.

The document and the proposals contained herein are the product of a working group of the Land Transport Standards Subcommittee and have not been endorsed by any of the participating governments within the NAFTA partnership.

Table of Contents

1. Background..... 4

2. Project Group Membership 4

**3. Safety Performance Criteria as a Consideration in Regulatory Harmonization -
Candidate Areas 5**

 3.1. Part 1: Highway Safety Criteria Directly Related to Vehicle Dimensions 6

 3.1.1. Overall Height 6

 3.1.2. Overall Width 7

 3.1.3. Overall Length..... 8

 3.1.4. Box Length 9

 3.1.5. Transient Low-Speed Offtracking..... 10

 3.1.6. Front Swingout 12

 3.1.7. Rear Swingout 14

 3.2. Part 2: Highway Safety Criteria Directly Related to Vehicle Weight..... 16

 3.2.1. Acceleration Performance 16

 3.2.2. Dynamic Axle Loading/Suspension Characteristics 17

 3.2.3. Bridge Overstress 17

 3.2.4. Productivity: Impact on Pavement Relative to Payload Carried 18

 3.3. Part 3: Criteria Directly Related to Both Vehicle Dimensions and Weights 19

 3.3.1. Load Transfer Ratio..... 19

 3.3.2. Transient High Speed Offtracking..... 21

 3.3.3. Friction Demand in Tight Turns..... 22

4. Regulatory Harmonization - Initial Priorities..... 23

5. Concluding Observations - Application and Implementation Issues..... 24

1. Background

Discussion of regulatory compatibility under NAFTA provides both an opportunity and a need to reflect upon the role and objectives of public policy in the area of vehicle weight and dimension limits. While the need for limits on the size and weight of highway transport vehicles which operate on public highways is not in question, the objectives of specific elements of regulatory policies are not always well understood. Consequently, the pursuit of harmonized regulatory policies between jurisdictions can best be considered when there is a clear and mutual understanding of the policy objectives being sought.

It is in this context that highway safety related performance criteria such as vehicle stability and control, pavement impacts and bridge capacity are under consideration by the NAFTA working group. Of particular interest is the feasibility of using safety performance criteria to help describe and quantify policy objectives, and for each criteria, to consider establishment of appropriate "performance targets" or acceptable thresholds.

As a first step in these considerations, in June 1998 LTSS Working Group 2 initiated a review of the literature and international experience in this area to provide a foundation for further discussion of the concept. A project group was formed to undertake this review and to prepare a report with recommendations on candidate criteria which would be relevant and appropriate considerations in the context of regulatory harmonization discussions under NAFTA.

2. Project Group Membership

Canada: Mr. Emile DiSanza, Transport Canada
Mr. Greg Gilks, Saskatchewan Highways and Transportation
Mr. John Pearson, Task Force on Vehicle Weights and Dimensions Policy

United States: Mr. Phil Blow, Federal Highway Administration
Mr. Dave Galt, Montana Department of Transportation
Mr. Mike Lynch, Texas Department of Transportation
Mr. Norman Schneider, New York Department of Transportation

Mexico: Mr. Antonio Jorge Capiz, Secretaria de Comunicaciones y Transportes
Mr. Alberto Mendoza, Mexican Transport Institute
Mr. Manual Muniz Y Marquez, SCT, Baja California

3. Safety Performance Criteria as a Consideration in Regulatory Harmonization - Candidate Areas

The discussion and information exchange by LTSS 2 over the past three years has served to document the regulatory controls which jurisdictions within NAFTA have placed on commercial vehicle dimensions and weights. It is evident that there are differing philosophies underlying truck weight and dimension regulation, and different judgements have been applied in determining acceptable limits.

In pursuit of an objective, technical basis for identification of regulatory harmonization opportunities, a series of safety performance criteria have been selected for further development. These criteria provide focus for discussion of why regulatory controls may be warranted, and if so, what specific limits would be appropriate to ensure vehicle performance falls within acceptable limits to ensure highway safety is enhanced.

In the context of the mandate of LTSS 2, it may be feasible to achieve broad-based consensus on the types of vehicle dimension and weight related regulatory controls which are warranted. However, it would be inappropriate to pursue absolute uniformity in the regulated limits for each control throughout North America. The design standards and physical characteristics of highway networks vary widely throughout the NAFTA partnership. These factors, coupled with widely ranging traffic volume and mix characteristics, support the premise that highway safety imperatives can be respected by adopting vehicle dimension and weight limits which are appropriate to local or regional conditions.

3.1. Part 1: Highway Safety Criteria Directly Related to Vehicle Dimensions

3.1.1. Overall Height

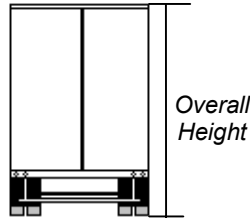

Limiting factors:

- compatibility with available vertical clearances on the roadway.
- impact on the stability of commercial vehicles which are designed to fully exploit the "dimensional envelope" described by the regulations (that is, impact on the height of a vehicle's centre of gravity)

Discussion:

An overall height limit on vehicles is clearly warranted to ensure there is adequate clearance between vehicles and overhead structures on the roadway. While selected routings within North America offer vertical clearances of 5 metres or greater, there are many sections on the national highway systems where vertical clearances are 4.3 metres or less.

Recommended IAN Standard: 4.15 m (13.61 ft)

Proposed Standard Definition:

Overall Height: Means the vertical distance between the highest point on the vehicle or combination of vehicles, including cargo, and the surface of the road

3.1.2. Overall Width

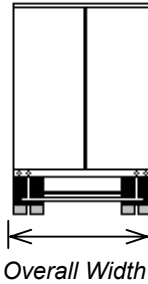

Limiting factors:

- compatibility with available space on the roadway, including factors such as lane width, shoulder width, horizontal clearances and horizontal curve radii
- impact on the stability of commercial vehicles; wider track axles improve rollover stability

Discussion:

An overall width limit on vehicles is needed to ensure that large commercial vehicles are compatible with the space available within a single lane on the public roadway system. While wider vehicles could be accommodated on selected high standard routings within North America, a considerable percentage of the highway network is based on a lane width of 3.0 metres or less.

Recommended IAN Standard: 2.60 m (102.36 in)

Proposed Standard Definition:

Overall Width: Means the greatest overall transverse dimension of a vehicle or combination of vehicles including load, but exclusive of devices or appurtenances at the sides of a truck, tractor, semitrailer, or trailer whose function is related to the safe operation of the vehicle. Such devices may extend no more than 10 centimeters beyond the side of the vehicle, and would include, but not necessarily be limited to:

- equipment used to secure cargo on a vehicle
- turn signal lamps
- hand-holds for cab entry/egress
- splash and spray suppressant devices
- load induced tire bulge
- devices designed to restrain vehicle wheels

Rear view mirrors are also excluded from width measurement, but must not extend more than 20 centimeters beyond the side of the vehicle.

3.1.3. Overall Length

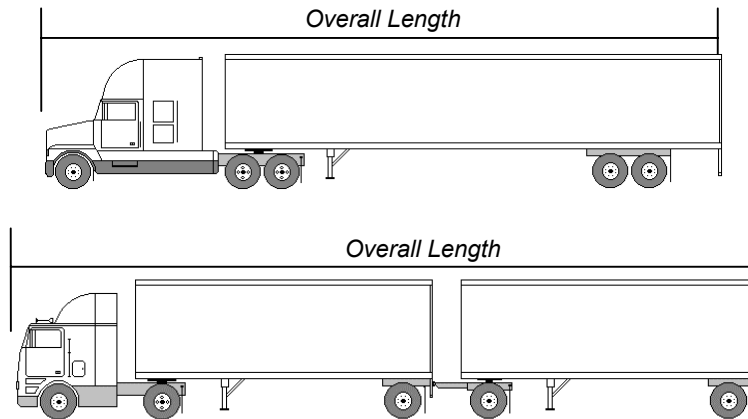

Limiting factors:

- the maximum length of vehicle which can be safely passed within the passing sight distance and passing zone striping practices
- compatibility of the highway geometry with the turning and manoeuvring characteristics of vehicles at the length limit selected.

Discussion:

It could be argued that an overall length limit on commercial vehicles is not required for multi-lane freeways, where passing opportunities for other vehicles are not dependent upon passing zones. However, within the NAFTA partnership a majority of the road networks in Mexico and Canada are two lane - two way roadways. Consequently, an overall length limit is required for these routes to ensure passing maneuvers can be safely accomplished within available sight distance and roadway striping controls.

**Recommended IAN Standards: Tractor-Semitrailer Combinations: 23.00 m (75.46 ft)
 Double Trailer Combinations: 25.00 m (82.0 ft)**

Proposed Standard Definition:

Overall Length: Means the longitudinal measurement from the foremost part of a vehicle or combination of vehicles, including cargo, to the rearmost part of the vehicle or combination of vehicles, including cargo

Definitional Issues:

- should the overall length limit be absolute, or should exemptions be provided for certain types of equipment from measurement of length (eg. safety devices, hydraulic lifts etc)?

3.1.4. Box Length

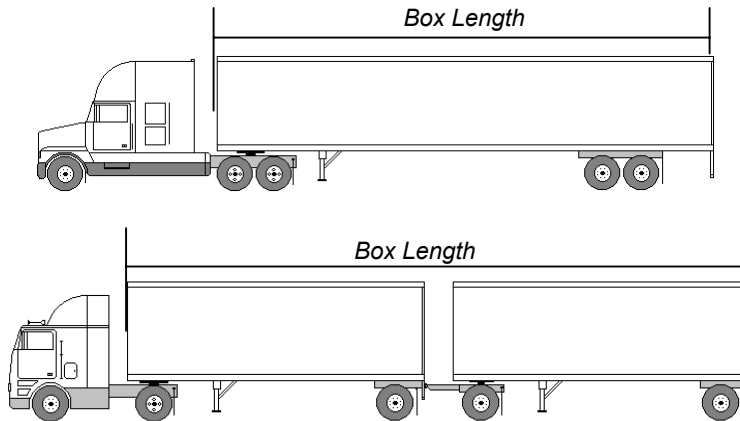

Constraining factors:

- the space required within the constraint of the overall length limit to fit a tractor which can be operated safely and comfortably by the driver
- standardization of equipment for fleet interchangeability and intermodal movement of trailers

Discussion:

While placing a limit on box length does not correlate directly to on-highway safety performance, it does provide a means to ensure that adequate space is available to use tractors which are designed for improved driver safety and comfort.

**Recommended IAN Standards: Tractor-Semitrailer Combinations: 16.20 m (53.15 ft)
 Double Trailer Combinations: 20.00 m (65.62 ft)**

Proposed Standard Definition:

Box Length: Means the longitudinal dimension from the forward most part of the cargo carrying unit(s) or load(s) to the rearmost part of the cargo carrying unit(s) or load(s), exclusive of any extension(s) in the dimension caused by auxiliary equipment or machinery at the front that is not designed for the transportation of goods

3.1.5. Transient Low-Speed Offtracking

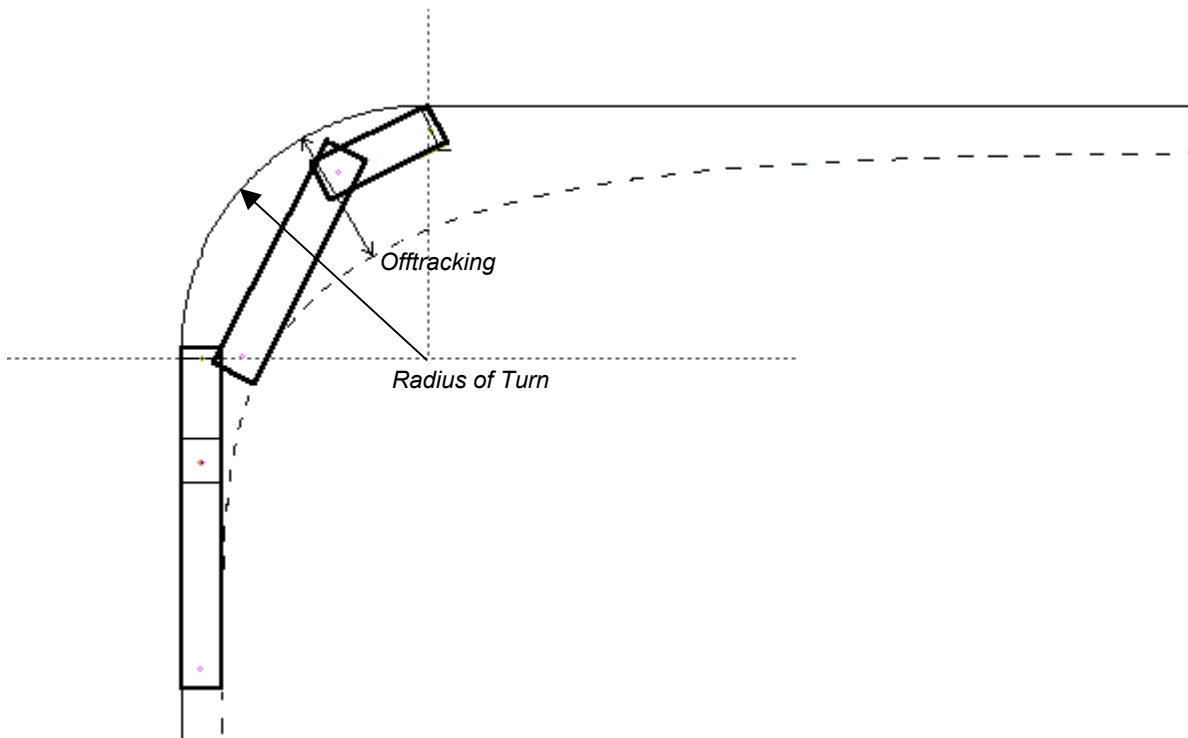

Limiting factors:

- the available space within a traffic lane, shoulder, intersection or entrance/exit ramp
- horizontal clearances to road furniture

Influencing factors:

- the radius of the turn
- the wheelbase of the truck or tractor
- the wheelbase of the trailer(s) or semitrailer(s) (the distance from the kingpin to the centre of the axle group on the semitrailer)
- the length of drawbar on trailers or converter dollies
- the position of the fifth wheel, and
- the speed of the vehicle

Discussion:

Regulatory measures are required to ensure that the low-speed turning performance of large vehicles is compatible with the available space at intersections and interchanges. However, implementation and enforcement of a true "performance based" standard for low-speed transient offtracking may be problematic. Nonetheless, without specific attention to this aspect of vehicle performance, evolution in vehicle dimensions will result in increases in turning space requirements which cannot be safely accommodated within the geometric constraints of existing highway geometry.

It is proposed that a low speed transient offtracking performance standard be established by

LTSS 2 as a basis for evaluating the desirability of current and future vehicle configurations. It is further proposed that this standard be based on two factors:

- the turning space available at intersections for typical high standard two lane arterial roads.
- the transient low speed offtracking performance of a typical tractor-semitrailer in wide spread usage (14.65 m - 48 ft trailer)

Recommended IAN Standard: No more than 5.60 m (18.3 ft) offtracking in a 90 degree turn of 14.00 m (45.9 ft) radius

Proposed Standard Definition:

Transient Low Speed Offtracking Performance Threshold: When a vehicle negotiates a 90° turn with an outside radius of 14.00 m, the maximum extent of lateral excursion of the last axle of the vehicle, relative to the path followed by the tractor steering axle, should not exceed 5.60 m.

Recommended Implementation Approach:

- place limits on the maximum acceptable wheelbases of tractors and trailers

3.1.6. Front Swingout

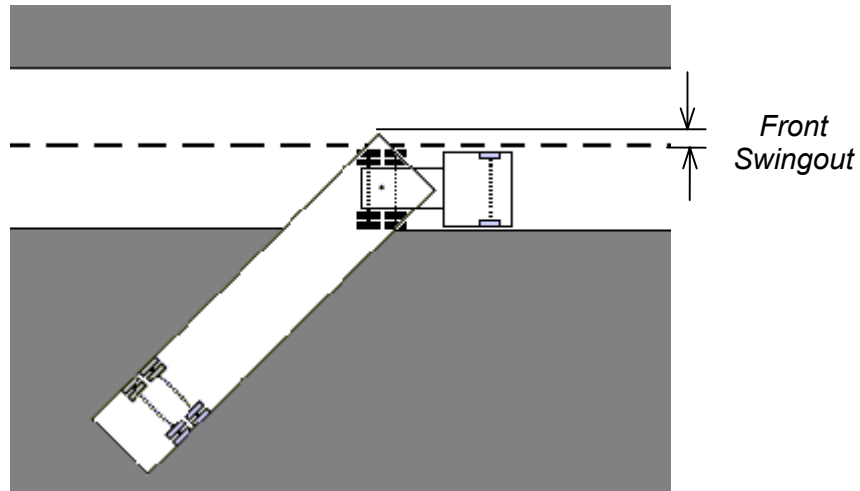

Limiting factors:

- the available space within a traffic lane

Influencing factors:

- the radius of the turn
- the position of the kingpin relative to the front of the trailer or semitrailer
- the front overhang of the cargo

Discussion:

As with offtracking, measures are required to ensure that the low-speed turning performance of large vehicles can be safely accommodated at intersections and interchanges and when turning on to a roadway. When turning on to a roadway, the front corner of the trailer may track outside the path followed by the tractor, and precaution is needed to ensure that there is no intrusion into the adjacent lane. However, the potential for intrusion into the oncoming traffic lane is of short duration, and is visible to the truck driver through the turn.

For these reasons, a more liberal acceptability threshold is proposed for front swingout than for rear swingout.

Recommended IAN Standard: No more than 0.45 m (18 in) front swingout in a 90 degree turn of 14.00 m (45.9 ft) radius

Proposed Standard Definition:

Front Swingout Performance Threshold: When a vehicle negotiates a 90° turn with an outside radius of 14.00 m, the maximum extent of excursion of the outside front corner of the vehicle or cargo relative to the path followed by the outside tractor drive tires, should not exceed 0.45 m.

Recommended Implementation Approach:

- place limits on:
 - the position of the trailer kingpin relative to the front of the trailer (ie. kingpin setback)
 - the amount of front overhang which is permitted

3.1.7. Rear Swingout

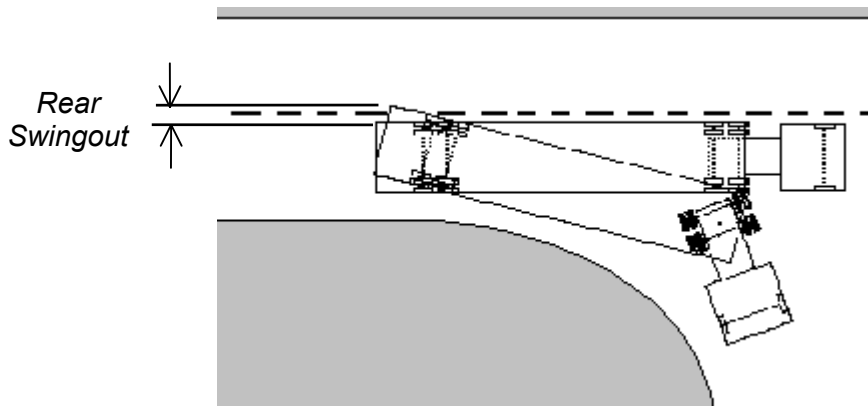

Limiting factors:

- the available space within a traffic lane

Influencing factors:

- the radius of the turn
- the wheelbase of the trailer or semitrailer (the distance from the kingpin to the centre of the axle group on the semitrailer)
- the effective rear-overhang of the trailer or semitrailer
- the rear overhang of the cargo

Discussion:

As with offtracking, measures are required to ensure that the low-speed turning performance of large vehicles can be safely accommodated at intersections and interchanges. Intrusion of the commercial vehicle into adjacent traffic lanes poses a threat to the safety of other drivers, particularly with swing-out of the rear of the trailer. Consequently, selection of an appropriate limit on rear swingout must include consideration of the fact that it occurs for a longer duration than swingout at the front of the trailer, and cannot be seen by the driver of the vehicle.

It is proposed that a rear swingout performance standard be established by LTSS 2 as a basis for evaluating the desirability of current and future vehicle configurations. It is further proposed that this standard be based on the manoeuvre proposed for transient low speed offtracking, with an acceptability threshold based on lane width turning space available at intersections for typical high standard two lane arterial roads.

Recommended IAN Standard: No more than 0.20 m (8 in) rear swingout in a 90 degree turn of 14.00 m (45.9 ft) radius

Proposed Standard Definition:

Rear Swingout Performance Threshold: When a vehicle negotiates a 90° turn with an outside radius of 14.00 m, the maximum extent of excursion of the outside rear corner of the vehicle or cargo relative to the path followed by the outside rear tires, should not exceed 0.20 m.

Recommended Implementation Approach:

- place limit on the effective rear overhang of trailer or cargo beyond the centre of the trailer axle group (eg. 35% of trailer wheelbase)

3.2. Part 2: Highway Safety Criteria Directly Related to Vehicle Weight

3.2.1. Acceleration Performance

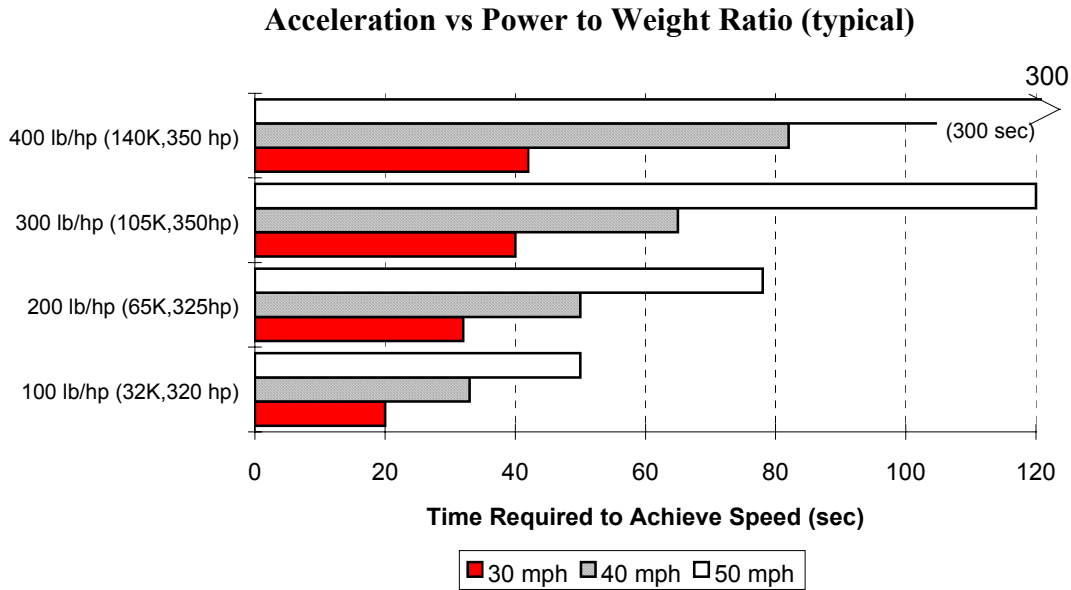

Limiting factors:

- Time available to clear intersections on green light cycle
- Merging with high speed traffic on freeways and arterials
- Maintaining speeds on grades
- Distance available for passing manoeuvres on two lane roads

Influencing factors:

- Engine horsepower
- Gross Vehicle Weight

Discussion:

The acceleration performance of heavy transport vehicles has some bearing on highway safety. However, as the current focus of LTSS 2 deliberations is on existing vehicles operating within a GVW cap of 80,000 lb, a performance standard is not warranted at this time. However, this measure is an important consideration relative to consideration of heavier weights, and potential impacts on the ability of a vehicle to enter traffic and maintain speeds on grades.

Recommended IAN Standard: None proposed at this time

3.2.2. Dynamic Axle Loading/Suspension Characteristics

Limiting factors:

- Pavement and bridge life cycle management

Influencing factors:

- Axle weight
- Vehicle speed
- Suspension damping characteristics

Discussion:

While this issue has been subject to considerable research in recent years, the policy implications of the research findings remain under study by OECD. It is recommended that consideration of a performance standard in this area be deferred pending completion of the work by OECD.

Recommended IAN Standard: None proposed at this time

3.2.3. Bridge Overstress

Limiting factors:

- bridge load bearing capacity
- acceptable levels of risk of failure

Influencing factors:

- Axle weight
- Gross Vehicle Weight
- Interaxle spacings

Discussion:

It is recognized that bridge capacity analysis procedures vary widely within the federal, state and provincial jurisdictions represented by the NAFTA partnership. There is little prospect of developing a commonly accepted methodology for assessing bridge capacity or for establishing a universally accepted overstress criterion. As the current focus of discussion is within the bridge capacity constraints provided by the US FHWA, no pressing action is needed by LTSS 2 in this area.

Recommended IAN Standard: As discussion of weight related issues has been deferred by the committee to allow initial focus on vehicle dimension related issues, no bridge overstress criteria threshold is proposed at this time. However, it is recommended that development of appropriate criteria and thresholds be accorded high priority in future discussions.

3.2.4. Productivity: Impact on Pavement Relative to Payload Carried

Limiting factors:

- Pavement structural capacity
- Pavement life cycle management
- Vehicle payload capacity

Influencing factors:

- number of axles
- axle group types and spacing
- axle and axle group weights

Discussion:

From a policy perspective, there is growing interest in development of an objective measure of the "productivity" of different vehicle configurations, in terms of the amount of payload carried relative to the vehicle's impact on pavement infrastructure. While this concept remains to be fully developed, it is predicated on calculating a vehicle's pavement impact in terms of "ESAL's".

Within the NAFTA partnership, further deliberations will be required to pursue this concept and to develop standard analysis protocols.

Recommended IAN Standard: As discussion of weight related issues has been deferred by the committee to allow initial focus on vehicle dimension related issues, no pavement impact related threshold is proposed at this time. However, it is recommended that consideration of performance criteria for pavement related impacts of heavy axle loads be accorded high priority in future discussions.

Issues:

- pursuit of this concept will require development and agreement on a common approach and methodology for calculating the Equivalent Single Axle Loads (ESAL's) for both axle groups and for whole vehicle configurations.
- consideration should also be given to gaining a common understanding of the relative impacts of different axle and tire configurations, including the use of single tires as an alternative to the more conventional dual tires.

3.3. Part 3: Criteria Directly Related to Both Vehicle Dimensions and Weights

3.3.1. Load Transfer Ratio

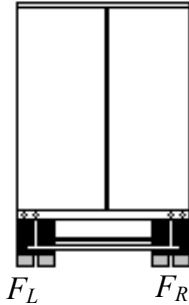

Explanation:

Dynamic Load Transfer Ratio characterizes the extent to which a vehicle approaches the rollover condition in a dynamic steering manoeuvre such as in avoiding an obstacle in the roadway. This measure is expressed in terms of the fractional change in tire loads between left- and right-side tires in the manoeuvre, thus indicating how close the vehicle came to lifting off all of its tires on one side, and rolling over. The Load Transfer Ratio is calculated as follows:

$$\text{Load Transfer Ratio} = \frac{\sum(F_L - F_R)}{\sum(F_L + F_R)}$$

F_L = Left side tire loads

F_R = Right side tire loads

Limiting factors:

- Maximum safe speeds on curves
- Speeds in lane change manoeuvres

Influencing factors:

- Payload centre of gravity height
- Number of trailers
- Trailer connection types
- Axle weights
- Trailer wheelbase (s)
- Suspension characteristics
- Track width
- Tire type and size

Discussion:

Strictly speaking, implementation and enforcement of a true "performance based" standard for load transfer ratio presents insurmountable challenges for North America. The stability performance of individual highway transport vehicles can vary from day to day, being influenced by changes in the volume and density of loads carried, interchange of tractors and trailers, and the condition of components such as suspension and tires.

Enforcement of a Load Transfer Ratio safety performance criterion would not be possible or

practical, given the nature of compliance verification facilities and the volume of trucks to be inspected. Nonetheless, as a regulatory principle, establishment of a Load Transfer Ratio performance criteria provides a benchmark for use in assessing the impacts of changes in weight or dimension limits for vehicle types currently in the fleet, or for considering the potential impacts of new types of vehicle configurations.

Recommended IAN Standard: It is proposed that a Load Transfer Ratio performance criteria be adopted as a regulatory principle by LTSS 2, with an acceptability threshold of a maximum of 0.60.

3.3.2. Transient High Speed Offtracking

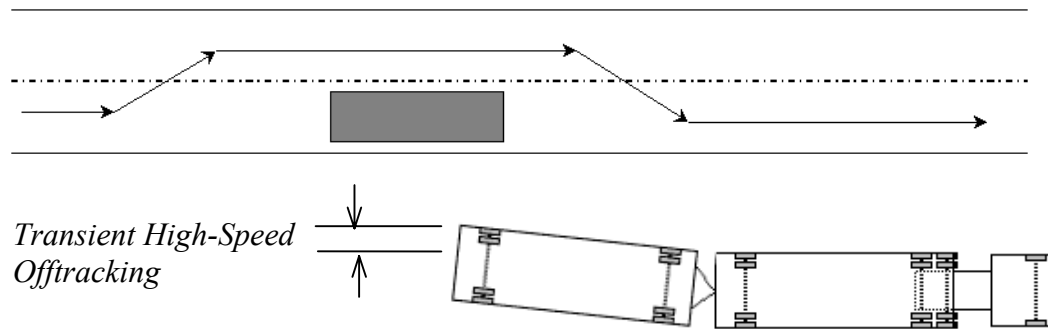

Explanation

This performance measure is obtained from the same obstacle avoidance manoeuvre used to assess Load Transfer Ratio. It is defined as the peak lateral overshoot of the rearmost trailer axle, following a severe lane-change-type maneuver. The amount of overshoot can be viewed as a relative indication of the extent of potential intrusion into an adjacent lane of traffic, or the potential for striking a curb (risking an impact-induced rollover).

Limiting factors:

- lane width

Influencing factors:

- Payload centre of gravity height
- Number of trailers
- Trailer connection types
- Axle weights
- Trailer wheelbase(s)
- Suspension characteristics
- Track width
- Tire type and size

Discussion:

The issues respecting a "performance based" standard for Transient High Speed Offtracking are similar to those discussed under the section on Load Transfer Ratio. For similar reasons it is proposed that Transient High Speed Offtracking be established as a regulatory principle in support of regulatory harmonization discussions under NAFTA.

Recommended IAN Standard: It is proposed that a Transient High-Speed Offtracking performance criteria be adopted as a regulatory principle by LTSS 2, with an acceptability threshold of a maximum of 0.8 metres (32 in).

3.3.3. Friction Demand in Tight Turns

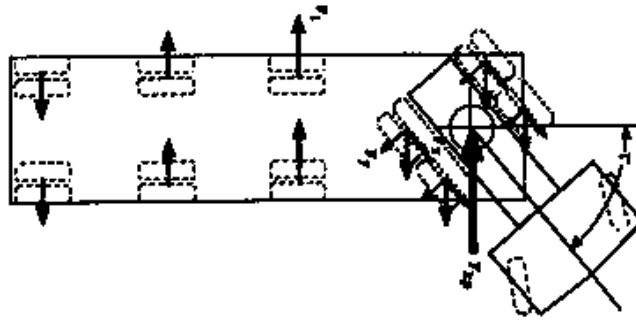

Explanation

This performance measure pertains to the resistance of multiple, non-steered axles to travelling around a tight-radius turn, such as at an intersection. The resistance to operating in a curved path results in a requirement, or demand, for tire side force at the tractor's drive axles, especially with semitrailers having widely spaced axles. When the pavement friction level is low, such vehicles may exceed the friction which is available and produce a jackknife-type response. The friction demand measure describes the minimum level of pavement friction on which the vehicle can negotiate an intersection turn without suffering such a control loss.

Limiting factors:

- tire / road surface coefficient of friction

Influencing factors:

- Number of axles on trailer
- Spacing of axles on trailer
- Axle weights

Discussion:

The implications of a performance standard for Friction Demand in Tight Turns are most directly related to the design of trailers. If regulatory policies encourage or provide payload incentives for designers to install multiple, widely spaced axles on trailers, this performance criterion becomes a relevant concern. However, as the initial focus for LTSS 2 is on 5 and 6 axle vehicle configurations, a performance criterion for Friction Demand is not warranted at this time.

Recommended IAN Standard: None proposed

4. Regulatory Harmonization - Initial Priorities

In its initial deliberations, LTSS Working Group 2 recognized that the majority of international truck transportation movements currently take place with 5 axle tractor-trailer combinations, usually configured to meet US weight and dimensional requirements and operating at gross weights of 80,000 lb. or less.

It is recognized that other vehicle configurations play important roles in international transportation within North America, particularly within regions where federal, provincial or state regulations are more liberal. However, in the context of addressing regulatory barriers which affect vehicles operating throughout the NAFTA partnership, configurations which can operate within the constraint of the US federal GVW limit of 80,000 lb. were selected as a first priority. These include:

Tractor Semitrailer - Five Axles

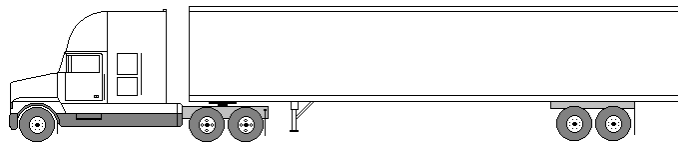

Tractor Semitrailer - Six Axles

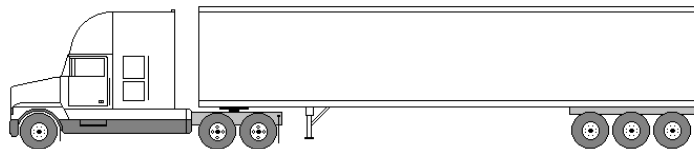

A Train Double Trailer Combination - 5 Axles

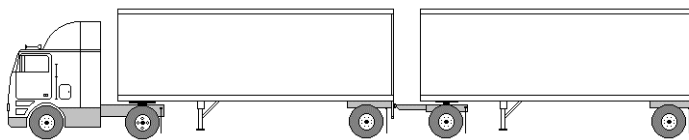

A Train Double Trailer Combination - 6 Axles

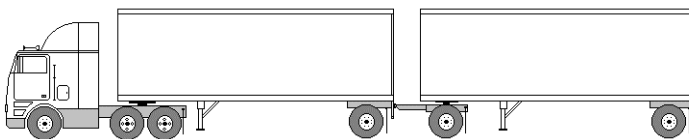

These configurations now operate extensively in all three countries on major highways, such as those designated in the United States for the National Network under the Surface Transportation Assistance Act (STAA) of 1982. For purposes of clarity, this system of major highways shall be referred to as the International Access Network (IAN).

5. Concluding Observations - Application and Implementation Issues

Conceptually, the safety performance criteria, thresholds, and vehicle dimension limits proposed in this report would:

- apply to selected major highways in Canada, the United States and Mexico. The responsibility for selecting highways for inclusion in the International Access Network (IAN) would rest with each of the administrations responsible for operating and maintaining portions of the highway network. In this context, highways which have physical characteristics or restrictions which are incompatible with the limits proposed would not be candidates for inclusion in the IAN.
- represent "minimum" standards which would be compatible with the highways included in the IAN. Highway administrations could choose to adopt or retain more liberal thresholds or dimension limits for routes under their jurisdiction which are included in the IAN.
- apply initially to operation of five and six axle tractor-semitrailer and double trailer combinations on the IAN, for the reasons discussed in Part 4.

Achieving consensus on appropriate safety performance criteria and accompanying thresholds would provide a technically sound basis for identifying an International Access Network in support of the efficient movement of highway transport vehicles within the NAFTA partnership. Agreement on common definitions for the application of dimension limit regulatory controls would also serve to address many of the current "administrative" barriers faced by carriers which operate between jurisdictions.

It is acknowledged that a large number of governments within North America have authority over, and responsibility for, vehicle size and weight limits on highways within their jurisdiction. The concepts described in this paper are not intended to challenge this authority, but rather are offered as a basis for discussion of opportunities to harmonize elements of public policy which:

- are essential for protection of the safety of all users of the public highway system(s), and
- are necessary to ensure the characteristics of freight vehicles are compatible with the highways they use, but
- may be impeding the efficiency of interjurisdictional travel because of differing policy approaches to the same objective

It is recognized and understood that consideration of legislative or regulatory changes in each of the local, state/provincial and federal governments within North America must follow prescribed and democratic processes.